

# A Non-Crimpable Archwire Hook

KEJIN LIU, DDS  
LI JI, DDS  
XIAOLONG ZHONG, DDS

**T**raditional crimpable archwire hooks are easily displaced and can even cause distortion of the archwire during their placement. We have developed a simple modification that avoids these drawbacks.

## Placement Procedure

Our non-crimpable archwire hook\* consists of a stainless steel, split box-form body with a hook and a separate, cone-shaped brass pin (Fig. 1). A cylindrical hole pierces the body from top to bottom. To attach the non-crimpable hook to the archwire:

1. Modify a standard needle holder by cutting off one-third of the jaws and splitting one jaw vertically (Fig. 2).
2. Insert the hook into the split in the jaw and use the needle holder to clamp the box-form body onto

\*Part No. 9121-A27, Hangzhou Shinye Odontology Materials Corporation Company, No. 16 XianDe Road, Gongshu District, Hangzhou, Zhejiang 310000, China; www.shinye-ortho.com.

the archwire (Fig. 3A).

3. After moving the hook to the desired position on the archwire, insert the pin into the cylindrical hole with its flat side facing the wire. Invert the needle holder and press the pin into the hole until it is fully seated and wedged against the archwire, with its terminal end protruding through the split in the needle-holder jaw (Fig. 3B).

4. To prevent loosening of the pin, bend back the terminal end so that it lies flat against the hook body (Fig. 3C).

## Discussion

The soft metal of traditional crimpable hooks is easy to deform, even with light clamping forces. Crimpable hooks are known to open and creep with the application of traction, especially labial or buccal forces. Excessive crimping forces can cause gabling of the archwire.<sup>1</sup> Our non-crimpable hook is made of harder metal, which requires more clamping force during placement, but also makes



Dr. Liu

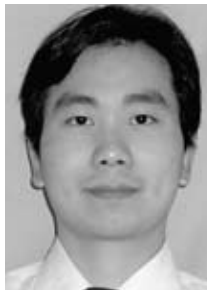

Dr. Ji



Dr. Zhong

Dr. Liu is a resident, Department of Science, Affiliated Stomatological Hospital of Southern Medical University and Guangdong Provincial Stomatological Hospital, Guangzhou, China. Dr. Ji is an attending orthodontist and Dr. Zhong is an Adjunct Associate Professor, Department of Orthodontics, First Affiliated Hospital, Sun Yat-sen University, No. 58, Zhongshan 2nd Road, Guangzhou 510080, China. E-mail Dr. Zhong at xzlpd@163.com.

## A Non-Crimpable Archwire Hook

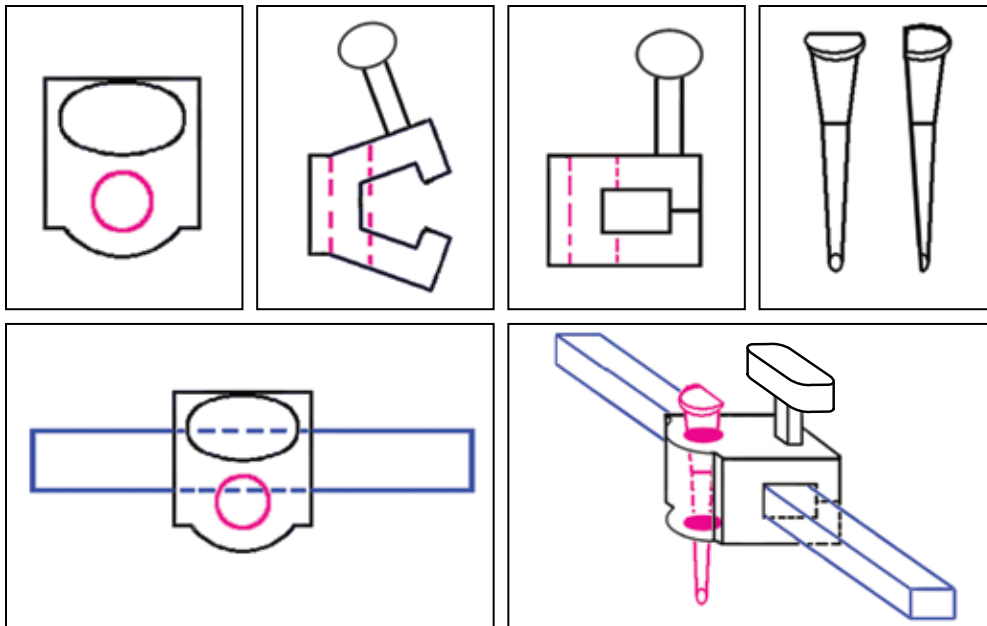

Fig. 1 Non-crimpable hook components in various views.

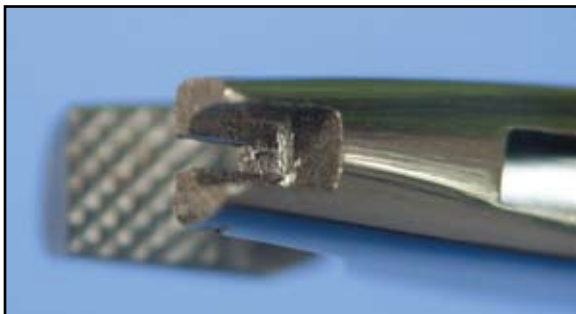

Fig. 2 Modified needle holder with one-third of jaws cut away and one jaw split vertically.

the hook much more resistant to sliding. Additional friction is created by the soft brass pin pressing against the archwire.

In a laboratory test, we attached 30 non-crimpable archwire hooks and 30 traditional crimpable hooks to 60 .019" × .025" stainless steel archwires. Each archwire-hook assembly was secured to a contact jig and passively mounted to the base of a universal testing machine. The hook was engaged by a stainless steel claw attached to the upper load cell of the machine and oriented

parallel to the archwire, then pulled until the hook was dislodged from the archwire. The non-crimpable archwire hooks were significantly more resistant to displacement than the traditional crimpable hooks: the mean force required to dislodge the non-crimpable hooks was  $22.37 \pm 9.06$  Newtons, compared with only  $4.96 \pm 0.70$  Newtons for the crimpable hooks ( $p < .001$ ). Details of the materials, methods, and results are published in an Appendix to the online version of this article at [www.jco-online.com](http://www.jco-online.com).

The SPEED archwire hook uses a “squeeze and lock” principle similar to that of our split non-crimpable hook, but it requires removal of the archwire for placement and a specific hook size for each archwire size, since the components of the SPEED hook are machined to a high level of precision.<sup>2</sup> With its soft, malleable brass pin attachment, our non-crimpable hook is more compatible with various sizes of commercially available archwires.

The non-crimpable hook requires no soldering or archwire removal and thus saves chairtime. It is especially useful in surgical cases where a hook needs to be placed quickly and securely. As with

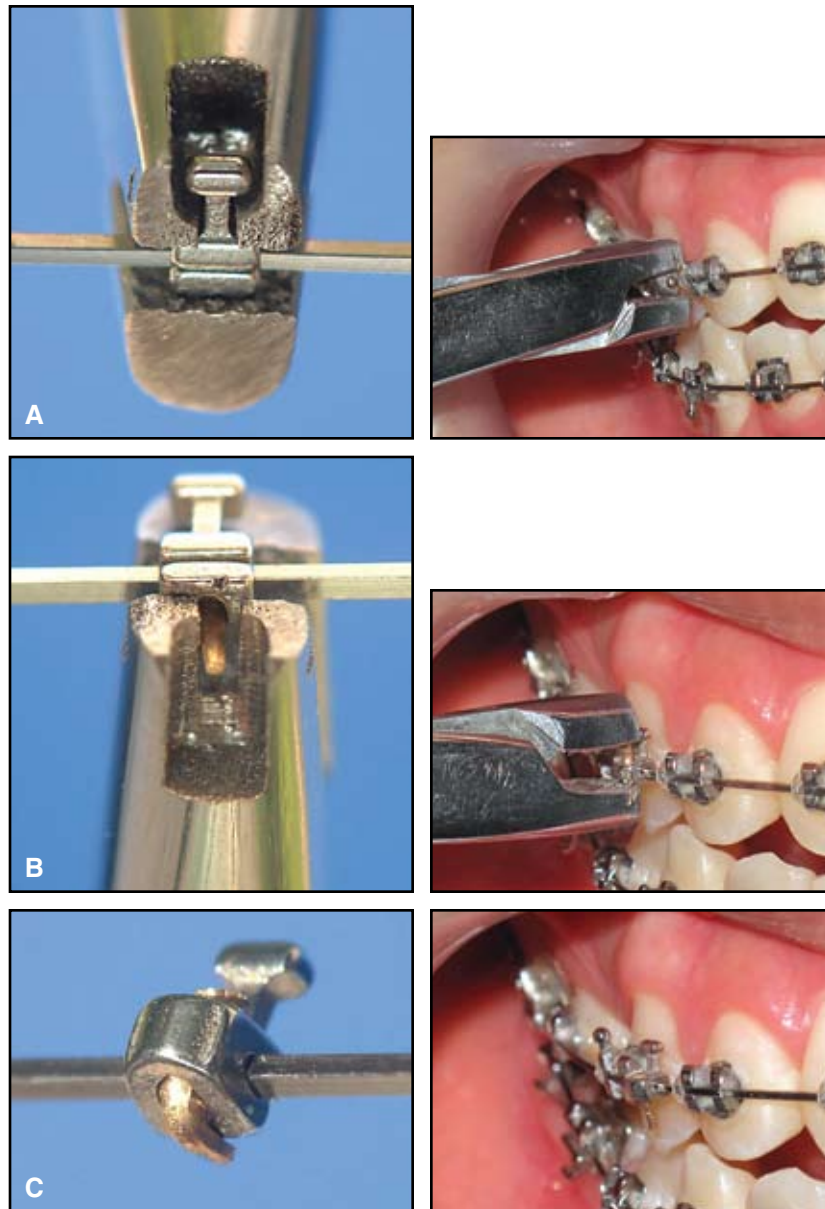

**Fig. 3** Placement of non-crimpable hook. **A.** Body clamped onto archwire. **B.** Brass pin inserted into cylindrical hole. **C.** End of pin bent back against hook.

any small orthodontic device, care should be taken to prevent swallowing or aspiration of the components—especially the brass pin, which is approximately the size of a Begg pin. We suggest placing a gauze square over the patient's throat area during placement and removal.

#### REFERENCES

1. Evans, R.D. and Jones, M.L.: A laboratory evaluation of surgical ball hook crimping pliers, *Int. J. Adult Orthod. Orthog. Surg.* 6:57-60, 1991.
2. Berger, J.: Archwire hooks for the SPEED System, *J. Clin. Orthod.* 31:354-357, 1997.